

# F18 SB



## Features



### PRESSURE GAUGE

Allows you to monitor the inlet and pump pressure during extraction.



### ELECTRONIC AUTO-LEVEL

Through an electronic auto level probe, the boiler is automatically filled and maintained to the right filling level.

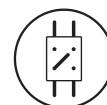

### STATIC RELAY BOILER TEMP.

Allows you to accurately regulate the temperature using a PID algorithm.



### AISI 316L STAINLESS STEEL "COOL TOUCH" STEAM WAND

Anti-burning feature for prolonged use, fitted with "Latte Art" high-performance steam terminals.



### LED LIGHTING OF THE WORK AREA

Allows efficient working in any condition of environmental lighting.



### PROGRAMMABLE CUP WARMER

Dedicated resistor to keep all cups at the optimal temperature.



### MIXED INFUSION HOT WATER FOR TEA

Immediate mixing of cold / hot water that allows for easy temperature adjustment.



### AUTOMATIC CLEANING CYCLE

Programmable process for cleaning the coffee groups.



### EASY SERVICE

Fast access to the internal parts for quick and easy technical service.



### MULTIFUNCTION DISPLAY

Allows you to monitor the right functioning of the machine and to program the machine's main functions.



### PROGRAMMABLE PRE-INFUSION

Control the water that hits the coffee bed with 0.1 sec tolerance, programmed for 4 different profiles for each group.



### HIGH-PERFORMANCE VOLUMETRIC PUMP

Pressure stability with prolonged use and simultaneously on more than one group.



### GROUP FLUSHING

With a simple button push a small quantity of water is dispensed.



### COMPETITION FILTERS

Exclusive Sanremo design, with shape and volume designed to capture the best coffee aromas and fragrances.



### ENERGY SAVING SYSTEM

Insulation and smart energy management to save up more than 20% of energy.



### GROUP SR 61

Chromed brass grouphead with thermosiphonic circulation system, optimised to maintain the ideal coffee extraction temperature.

Technical data		2 GROUP 20AMP	2 GROUP 25AMP*	3 GROUP
voltage	V	220-240 1N 50/60Hz or 380-415 3N 50/60Hz		
required amperage	A	20	25	32
power input	kW	4.4	4.9	6.5
steam boiler capacity	lt	12	12	18
steam boiler element	kW	4	4.5	6
pump power	kW	0.15	0.15	0.15
cup-warmer power	kW	0.20	0.20	0.25
net weight	kg	90	90	103

\*pre-order only



# F18 SB



## Versions

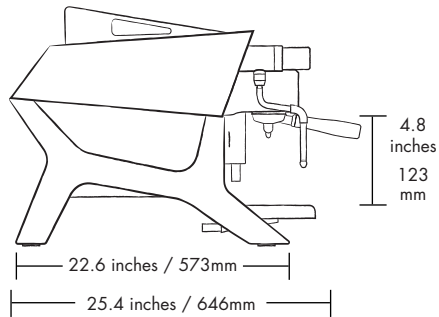

2 GROUP	3 GROUP
2 steam taps	2 steam taps
1 water tap	1 water tap
1 one-cup portafilter	1 one-cup portafilter
2 two-cup portafilters	3 two-cup portafilters

### 2 GROUP

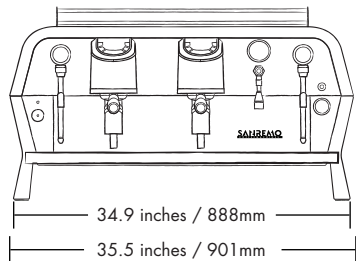

### 3 GROUP

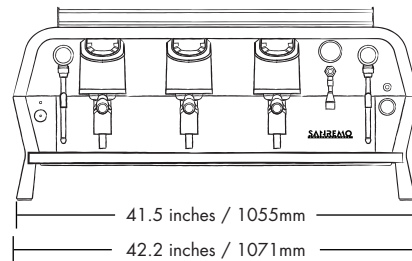

## Colours

	Black / Matte Black
	Black / Matte White



All images are subject to illustrative purpose. The manufacturer reserves the right to modify without prior notice the technical characteristics indicated above.

## Control Panel

### 5 SELECTION KEYBOARD

#### DOSES (1,2)

Single / Double

#### DOSES (3,4)

Single / Double

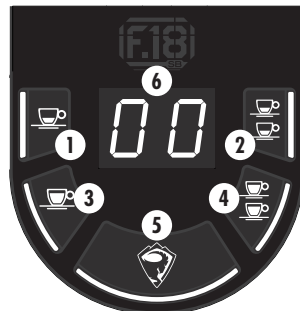

#### SHOT CLOCK (6)

coffee extraction time

CONTINUOUS DELIVERY /  
GROUP FLUSHING (5)

### MULTI-FUNCTION DISPLAY



### ECO MODE



## CONTACT US

info@sanremomachines.com.au  
sanremomachines.com.au

